

Ultrasonic sensor **UR30** Synchronous series

Feature Description

- ◆ M30 installation threaded sleeve
- ◆ Synchronization function
- ◆ 1 NPN or PNP switch output
- ◆ Analog voltage output 0-5/10V or analog current output 4-20mA
- ◆ Digital TTL output
- ◆ Output can be changed through serial port upgrade
- ◆ Setting detection distance through teach-in lines
- ◆ Temperature compensation

Model specifications

NPN NO/NC	UR30-CC50DNBS-E5	UR30-CM2DNBS-E5	PNP NO/NC	UR30-CC50DPBS-E5	UR30-CM2DPBS-E5
NPN Hysteresis mode	UR30-CC50DNHS-E5	UR30-CM2DNHS-E5	PNP Hysteresis mode	UR30-CC50DPHS-E5	UR30-CM2DPHS-E5
0-5V Analog output	UR30-CC50DU5S-E5	UR30-CM2DU5S-E5	4-20mA Analog output	UR30-CC50DIS-E5	UR30-CM2DIS-E5
0-10V Analog output	UR30-CC50DU10S-E5	UR30-CM2DU10S-E5	Com TTL232	UR30-CC50DTS-E5	UR30-CM2DTS-E5

Specifications

Sensing range	50-500mm	120-2000mm	Angle	±4°
Blind area	0-50mm	0-120mm	Indication	LED red light: working state:error;teach-in state:no target detected LED yellow light:always on;switch output; flashing: teach-in state LED green light: always on:power on; flashing:target detected
Resolution ratio	0.5mm			
Repeat accuracy	±0.15% of full scale value		Input type	With teach-in function
Absolute accuracy	±1% (temperature drift compensation)		Ambient temperature	-25°C...70°C(248-343K)
Response time	50ms*N (synchronous number N≤5)		Storage temperature	-40°C...85°C(233-358K)
Switch hysteresis	2mm		Characteristics	Support serial port upgrade and change the output type
Switching frequency	20/n Hz (synchronous number N≤5)		Material	Copper nickel plating, plastic accessory
Power on delay	<500ms		Protection degree	IP67
Working voltage	9...30VDC		Connection	5 pin M12 connector
No-load current	≤25mA			

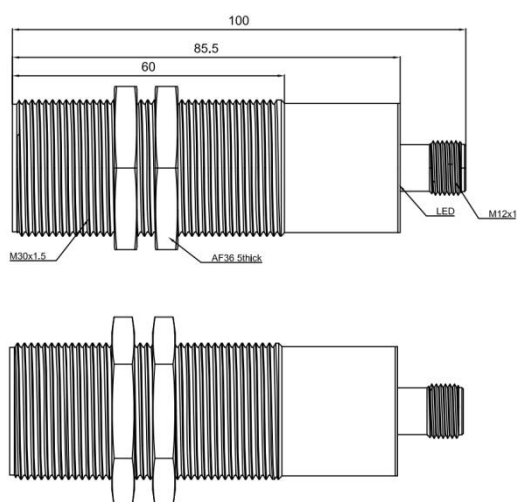
Dimension

Wiring diagram
