

Miniature photoelectric sensor PSV series



Feature description

- Small size, easy to install and use
- With 360° visible bright LED status indicator
- Superior anti-light interference, stable product performance
- Red light source for easy adjustment and alignment



Model specification

NPN NO	PSV-SR25DNOR	PNP NO	PSV-SR25DPOR
NPN NC	PSV-SR25DNCR	PNP NC	PSV-SR25DPCR

Specifications

Detection distance	25mm ^③	Response time	<1ms
Dead zone	<2mm	Anti ambient light	Sunlight interference ≤10,000 lux
Standard test body	0.1mm Copper wire(at the detection distance of 10mm)		Incandescent light interference ≤3,000 lux
Hysteresis	<20%	Operating temperature	-20...55 °C
Supply voltage	10...30V DC	Storage temperature	-30...70 °C
Consumption current	≤15mA	Protection degree	IP65
Load current	≤50mA	Certification	CE
Voltage drop	<1.5V	Shell material	PC+PBT
Light source	Red light(640nm)	Lens	PC
Protection circuit	Short circuit protection,Polarity protection	Weight	22g
	Overload protection,Zener protection	Accessory	Screws(M2×8mm)×2、 Nut×2
Indicator	Green:power,stable indicator;Yellow:output indicator		

③Use 50*50mm white card with reflectivity greater than 90%

Dimension

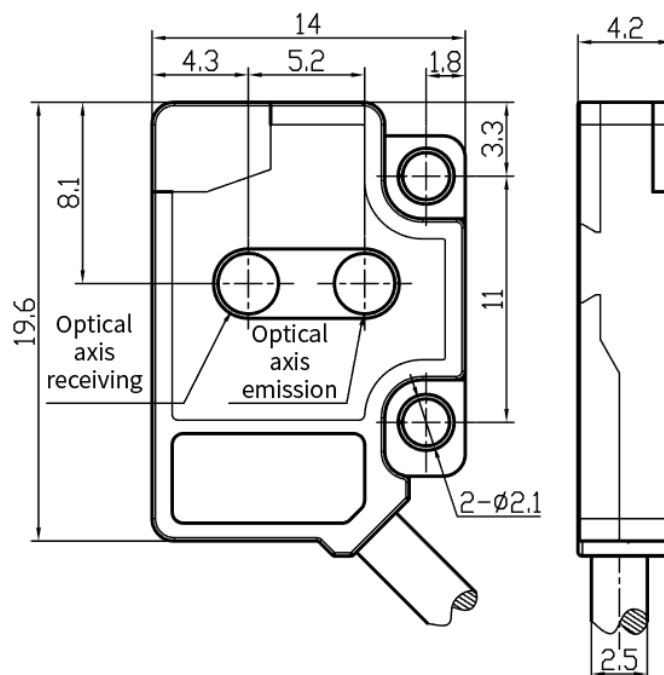

Wiring diagram

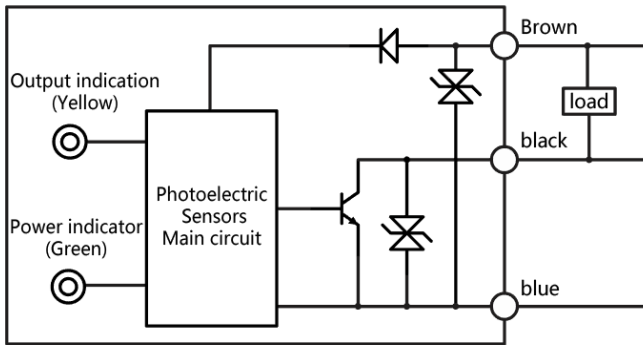

NPN

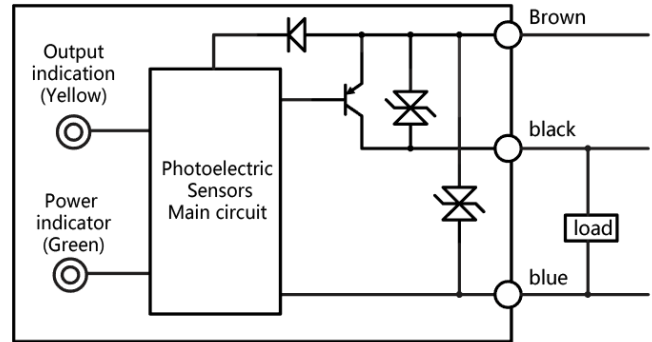

PNP