

# Miniature photoelectric sensor PSV series



## Feature description

- Small size, easy to install and use
- With 360° visible bright LED status indicator
- Superior anti-light interference, stable product performance
- Red light source for easy adjustment and alignment



## Model specification

NPN NO	PSV-BC10DNOR	PNP NO	PSV-BC10DPOR
NPN NC	PSV-BC10DNCR	PNP NC	PSV-BC10DPCR

## Specifications

Detection distance	10cm <sup>Ⓞ</sup>	Indicator	Green:power,stable indicator;Yellow:output indicator
Dead zone	<5mm	Response time	<1ms
Standard test body	50*50mm white cards	Anti ambient light	Sunlight interference ≤10,000 lux
Light spot size	15mm@10cm		Incandescent light interference ≤3,000 lux
Hysteresis	3...20%	Operating temperature	-20...55 °C
Supply voltage	10...30V DC	Storage temperature	-30...70 °C
Consumption current	≤15mA	Protection degree	IP65
Load current	≤50mA	Certification	CE
Voltage drop	<1.5V	Shell material	PC+PBT
Light source	Red light(640nm)	Lens	PC
Protection circuit	Short circuit protection,Polarity protection	Weight	22g
	Overload protection,Zener protection	Accessory	Screws(M2×8mm)×2, Nut×2

ⓄUse 50\*50mm white card with reflectivity greater than 90%

## Dimension

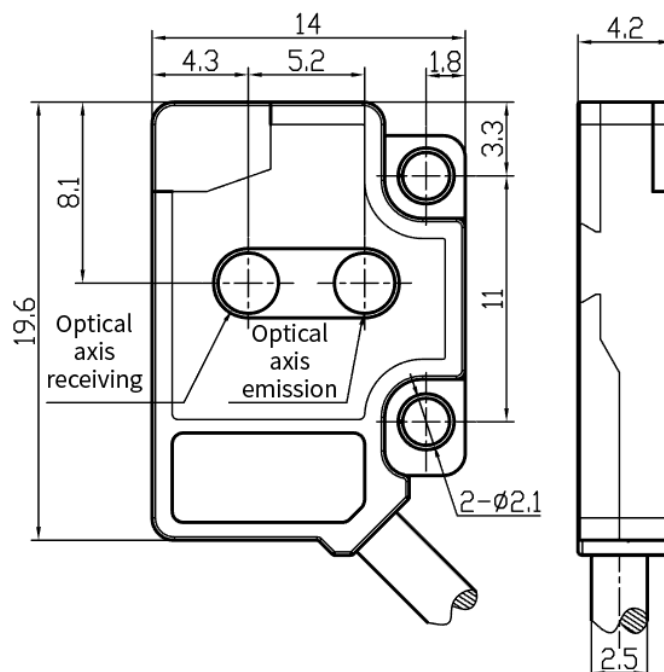

**Wiring diagram**

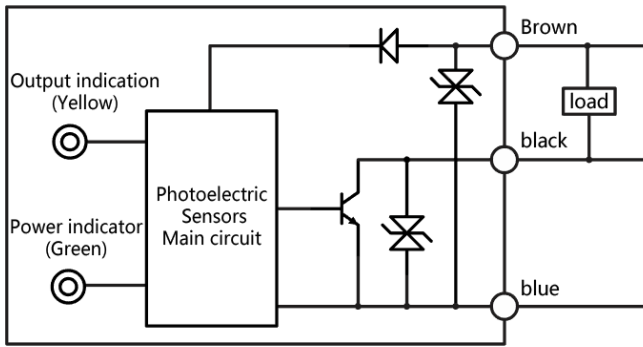

NPN

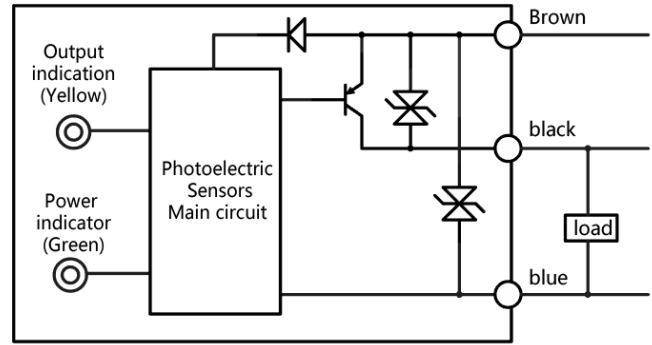

PNP