

Small size photoelectric sensors PSS series



Features

- 18mm threaded cylindrical mounting, easy to install
- Short case for small installation space
- Big knob design for easy adjustment;
- IP67 protection, suitable for harsh environments;
- Small detection blind zone, applicable to detection of objects in bright background;



Model

NPN NO/NC	PSS-BC10DNB-E2	PNP NO/NC	PSS-BC10DPB-E2
-----------	----------------	-----------	----------------

Specifications

Detection type	Diffuse reflection	Hysteresis	3...20%
Rated distance	10cm	Indicator	Green LED: power, stable Yellow LED: output, short circuit or overload
Light source	Infrared (940nm)	Anti-ambient light	Anti-sunlight interference ≤ 10,000lux; Incandescent light interference ≤ 3,000lux
Output	NPN NO/NC or PNP NO/NC	Operating temperature	-25...55 °C
Response time	≤0.5ms	Storage temperature	-35...70 °C
Supply voltage	10...30 VDC	Protection degree	IP67
Consumption current	≤20mA	Certification	CE
Load current	≤200mA	Material	Housing: PC+ABS; Filter: PMMA
Voltage drop	≤1V	Annex	M18 nut (2PCS), instruction manual
Circuit protection	Short-circuit, overload, reverse polarity protection		
Connection	M12 4-core connector		
Distance adjustment	Single-turn potentiometer		
NO/NC adjustment	Feet 2 is connected to the positive pole or hang up, NO mode; Feet 2 is connected to the negative pole, NC mode		

Remarks:①Detection object is 90% white card with size 20cm * 20cm;

②The green LED becomes weaker, which means that the signal is weaker and the sensor is unstable; The yellow LED flashes, which means that the sensor is shorted or overloaded;

Dimensions

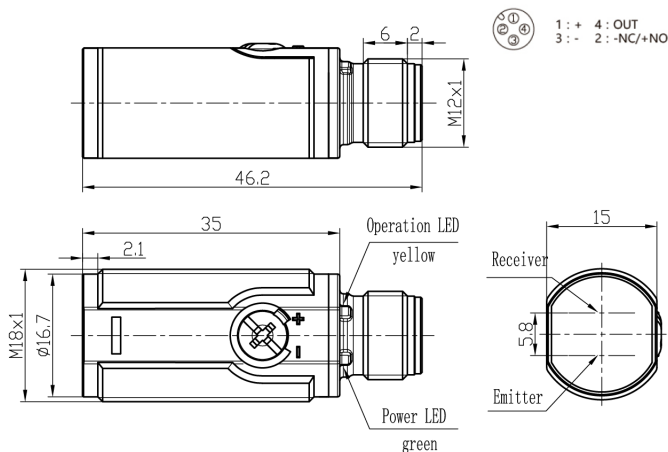

Circuit Diagrams

