

Small size photoelectric sensors PSM series



Features

- Universal housing, an ideal replacement for a wide range of sensor types;
- IP67, suitable for harsh environments;
- Fast and stable setting;
- NO and NC are switchable;
- Visible light spots for easy installation and commissioning.



Model

NPN NO/NC	PSM-BC40DNB	PNP NO/NC	PSM-BC40DPB
-----------	-------------	-----------	-------------

Specifications

Detection type	Diffuse reflection	Hysteresis	3...20%
Rated distance	40cm	Indicator	Green light: power, stable signal (unstable signal flash)
Light source	Infrared (940nm)		Yellow light: output, overload or short circuit (flash)
Output	NPN NO/NC or PNP NO/NC	Anti-ambient light	Anti-sunlight interference $\leq 10,000\text{lux}$; Incandescent light interference $\leq 3,000\text{lux}$
Response time	$\leq 0.5\text{ms}$	Operating temperature	$-25...55\text{ }^\circ\text{C}$
Supply voltage	10...30 VDC	Storage temperature	$-35...70\text{ }^\circ\text{C}$
Consumption current	$\leq 20\text{mA}$	Protection degree	IP67
Load current	$\leq 200\text{mA}$	Certification	CE
Voltage drop	$\leq 1\text{V}$	Material	Housing: Nickel copper alloy; Filter: PMMA
Distance adjustment	Single-turn potentiometer	Annex	M18 nut (2PCS), instruction manual
Circuit protection	Short-circuit, overload, reverse polarity protection		
Connection	2m PVC cable		
NO/NC adjustment	White wire is connected to the positive pole, NO mode; White wire is connected to the negative pole, NC mode		

Dimensions

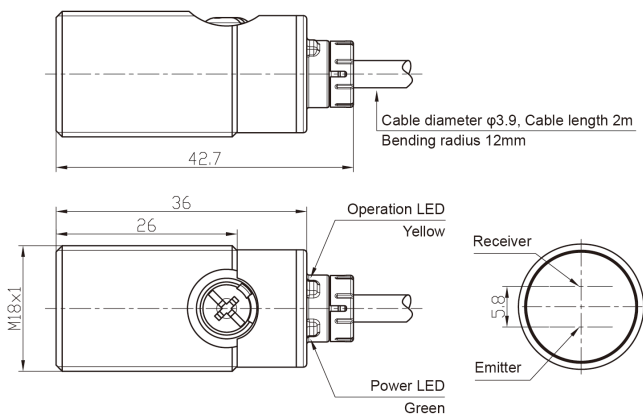

Circuit Diagrams

