

Small size photoelectric sensors PSM series



Features

- Universal housing, an ideal replacement for a wide range of sensor types;
- IP67, suitable for harsh environments;
- Fast and stable setting;
- NO and NC are switchable;
- Visible light spots for easy installation and commissioning.



Model

NPN NO/NC	PSM-BC40DNB-E2	PNP NO/NC	PSM-BC40DPB-E2
-----------	----------------	-----------	----------------

Specifications

Detection type	Diffuse reflection	Hysteresis	3...20%
Rated distance	40cm	Indicator	Green LED: power, stable
Light source	Infrared (940nm)		Yellow LED: output, short circuit or overload
Output	NPN NO/NC or PNP NO/NC	Anti-ambient light	Anti-sunlight interference ≤ 10,000lux; Incandescent light interference ≤ 3,000lux
Response time	≤0.5ms	Operating temperature	-25...55 °C
Supply voltage	10...30 VDC	Storage temperature	-35...70 °C
Consumption current	≤20mA	Protection degree	IP67
Load current	≤200mA	Certification	CE
Voltage drop	≤1V	Material	Housing: Nickel copper alloy; Filter: PMMA
Distance adjustment	Single-turn potentiometer	Annex	M18 nut (2PCS), instruction manual
Circuit protection	Short-circuit, overload, reverse polarity protection		
Connection	M12 4-core connector		
NO/NC adjustment	Feet 2 is connected to the positive pole, NO mode; Feet 2 is connected to the negative pole, NC mode		

Remarks:①Detection object is 90% white card with size 20cm * 20cm;

②The green LED becomes weaker, which means that the signal is weaker and the sensor is unstable; The yellow LED flashes, which means that the sensor is shorted or overloaded;

Dimensions

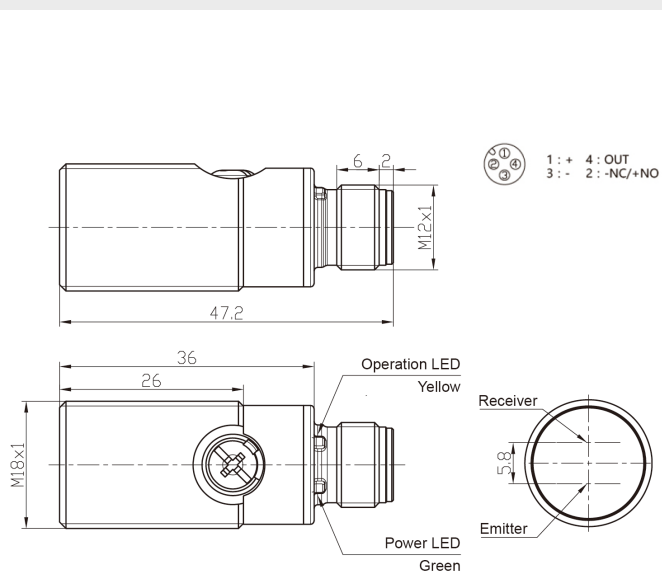

Circuit Diagrams

