

Small size photoelectric sensors PSM series



Features

- 18mm threaded cylindrical mounting, easy to install
- Short case for small installation space
- Big knob design for easy adjustment;
- IP67 protection, suitable for harsh environments;
- Small detection blind zone, applicable to detection of objects in bright background;



Model

NPN NO/NC	PSM-BC10DNB-E2	PNP NO/NC	PSM-BC10DPB-E2
-----------	----------------	-----------	----------------

Specifications

Detection type	Diffuse reflection	Hysteresis	3...20%
Rated distance	10cm	Indicator	Green LED: power, stable
Light source	Infrared (940nm)		Yellow LED: output, short circuit or overload
Output	NPN NO/NC or PNP NO/NC	Anti-ambient light	Anti-sunlight interference $\leq 10,000\text{lux}$;
Response time	$\leq 0.5\text{ms}$		Incandescent light interference $\leq 3,000\text{lux}$
Supply voltage	10...30 VDC	Operating temperature	-25...55 °C
Consumption current	$\leq 20\text{mA}$	Storage temperature	-35...70 °C
Load current	$\leq 200\text{mA}$	Protection degree	IP67
Voltage drop	$\leq 1\text{V}$	Certification	CE
Circuit protection	Short-circuit, overload, reverse polarity protection	Material	Housing: Nickel copper alloy; Filter: PMMA
Connection	M12 4-core connector	Annex	M18 nut (2PCS), instruction manual
Distance adjustment	Single-turn potentiometer		
NO/NC adjustment	Feet 2 is connected to the positive pole or hang up, NO mode; Feet 2 is connected to the negative pole, NC mode		

Remarks: ①Detection object is 90% white card with size 20cm * 20cm;

②The green LED becomes weaker, which means that the signal is weaker and the sensor is unstable; The yellow LED flashes, which means that the sensor is shorted or overloaded;

Dimensions

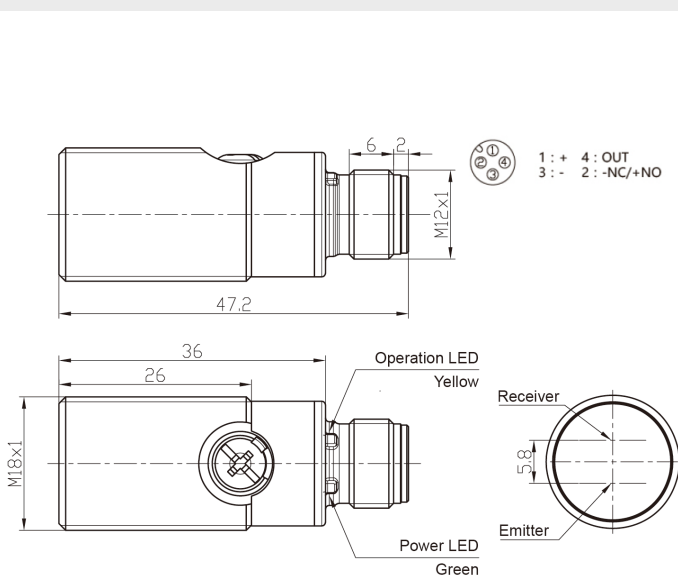

Circuit Diagrams

