

Plastic square shape inductive sensors **LE82** series

Features

- ◆ Non contact detection, safe and reliable;
- ◆ ASIC design;
- ◆ Perfect choice for metallic targets detection;



Part number

NPN NO	LE82VF15DNO	PNP NO	LE82VF15DPO
NPN NC	LE82VF15DNC	PNP NC	LE82VF15DPC

Technical specifications

Mounting	Flush	Current consumption	≤10mA
Rated distance [Sn]	1.5mm	Circuit protection	Reverse polarity protection
Assured distance [Sa]	0...1.2mm	Output indicator	Yellow LED
Dimensions	8 * 8 * 40 mm	Ambient temperature	-25°C...70°C
Output	NO/NC(depends on part number)	Ambient humidity	35-95%RH
Supply voltage	10...30 VDC	Switching frequency [F]	2000 Hz
Standard target	Fe 8*8*1t	Voltage withstand	1000V/AC 50/60Hz 60s
Switch-point drifts [%/Sr]	≤ ± 10%	Insulation resistance	≥50MΩ(500VDC)
Hysteresis range [%/Sr]	1...20%	Vibration resistance	10...50Hz (1.5mm)
Repeat accuracy [R]	≤3%	Degree of protection	IP67
Load current	≤100mA	Housing material	Aluminum alloy
Residual voltage	≤2.5V	Connection type	2m PVC cable

Dimensions

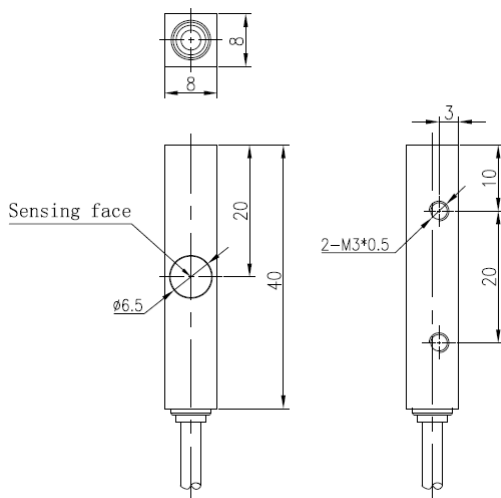

Wiring diagram

