

Plastic square shape inductive sensors **LE40XZ** series

Features

- ◆ Non contact detection, safe and reliable;
- ◆ ASIC design;
- ◆ Perfect choice for metallic target detection;



Part number

AC 2 wires NO LE40XZSF15ATO-E2 LE40XZSN20ATO-E2	AC 2 wires NC LE40XZSF15ATC-E2 LE40XZSN20ATC-E2
---	---

Technical specifications

Mounting	Flush	Non-flush	Leakage current [I _r]	≤3mA
Rated distance [S _n]	15mm	20mm	Circuit protection	...
Assured distance [S _a]	0...12mm	0...16mm	Output indicator	Yellow LED
Dimensions	40 *40*129 mm		Ambient temperature	-25°C...70°C
Output	NO/NC(depends on part number)		Ambient humidity	35-95%RH
Supply voltage	20...250V AC		Switching frequency [F]	20 Hz 20 Hz
Standard target	Fe 45*45*1t	Fe 60*60*1t	Voltage withstand	1000V/AC 50/60Hz 60S
Switch-point drifts [%/Sr]	≤ ± 10%		Insulation resistance	≥50MΩ (500VDC)
Hysteresis range [%/Sr]	1...20%		Vibration resistance	10...50Hz (1.5mm)
Repeat accuracy [R]	≤3%		Degree of protection	IP67
Load current	≤300mA		Housing material	PBT
Residual voltage	≤10V		Connection type	M12 connector

Dimensions

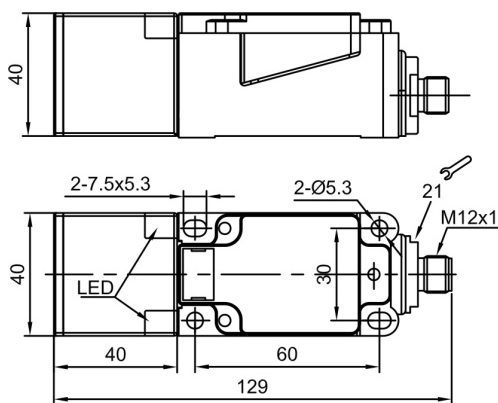

Wiring diagram

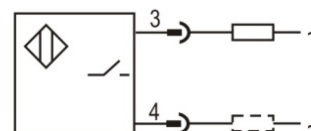

NO

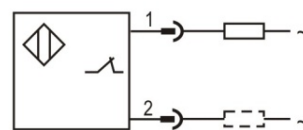

NC

