

Plastic square shape photoelectric sensors **PTE** series

Features

- ◆ Diffuse reflection working principle;
- ◆ Excellent anti-interference performance
- ◆ High detection accuracy

Part number

Relay output	PTE-BC30SK-E5	PTE-BC200SK-E5
--------------	---------------	----------------

Technical specifications

Detection type	Diffuse reflection	Consumption current	≤35mA
Rated distance [Sn]	30cm(adjustable)200cm (adjustable)	Circuit protection
Standard target	White card reflection rate 90%	Response time	< 10ms
Light source	Infrared LED (850nm)	Output indicator	Power: Green LED Output: Yellow LED
Dimensions	50 mm *50 mm *18mm	Ambient temperature	-25°C...+55°C
Output	Relay output	Ambient humidity	35-85%RH (non-condensing)
Supply voltage	24...240VAC/DC	Voltage withstand	2000V/AC 50/60Hz 60s
Target	Opaque object	Insulation resistance	≥50MΩ(500VDC)
Hysteresis range [%/Sr]	3...20%	Vibration resistance	10...50Hz (0.5mm)
Repeat accuracy [R]	≤5%	Degree of protection	IP67
Load current	≤3A	Housing material	PC/ABS
Residual voltage	Connection type	M12 Connector

Dimensions

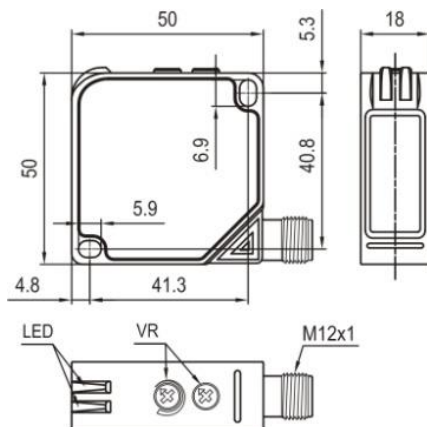

Wiring diagram

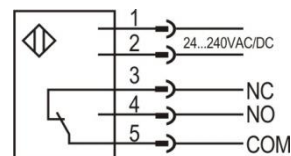

Relay output

