

## Plastic square capacitive sensor CE17 series

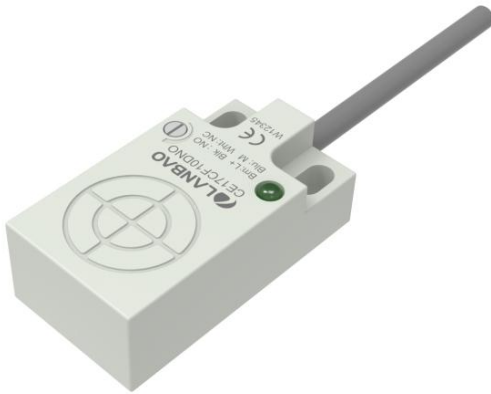

### Features:

- Can detect metal and non-metal material objects, more widely used.
- Response frequency up to 100Hz.
- Fast and accurate sensitivity adjustment with multi-turn potentiometer.
- Detection distance up to 8mm.



### Part number

NPN NO	CE17SN08DNOY	PNP NO	CE17SN08DPOY
NPN NC	CE17SN08DNCY	PNP NC	CE17SN08DPCY

### Technical specifications

Installation type	Non-flush	Residual voltage	$\leq 2.5V$
Rated distance	8mm	Consumption current	$\leq 5mA$
Adjust the distance	3...12mm(Adjustable)	Circuit protection	Short circuit protection, overload protection, reverse polarity protection
Adjustment method	Multi-turn potentiometer	Output indication	Yellow
Shape specification	32*17*10.5 mm	Switching frequency	100Hz
Output type	NPN/PNP NO/NC	Vibration resistant	Complex amplitude 1.5mm 10...50Hz(2 hours each in X, Y, and Z directions)
Supply voltage	10...30VDC	Impulse withsand	30G/11ms, 3 times each for X, Y, Z direction
Standard target	Fe 25*25*1t(Grounded)	Protection degree	IP54
Switch point offset	$\leq \pm 10\%$	Housing material	ABS
Hysteresis range	3...20%	Connection type	2m PVC cable
Repetitive error	$\leq 5\%$		
Load current	$\leq 150mA$		

### Dimensions

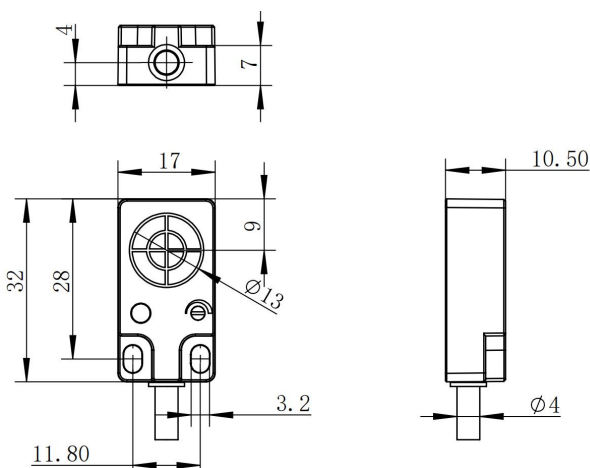

### Wiring diagram

