

## Capacitive sensors **CE15** series for pipeline liquid level detecting



### Features

- ◆ U type design for easier installation and detection
- ◆ Be able to detect various media via nonmetallic container;
- ◆ Widely applied in container detecting;

### Part number

NPN NO	CE15SN26DNO	PNP NO	CE15SN26DPO
NPN NC	CE15SN26DNC	PNP NC	CE15SN26DPC

### Technical specifications

Mounting	Non-flush	Consumption current	≤15mA
Rated distance [Sn]	... ..	Circuit protection	Short-circuit, overload and Reverse polarity
Assured distance [Sa]	.....	Output indicator	Yellow LED
Dimensions	34*33*20mm	Ambient temperature	-10°C...55°C
Output	NO/NC(depends on part number)	Ambient humidity	35-95%RH
Supply voltage	10...30 VDC	Switching frequency [F]	60 Hz
Applicable pipeline	Non-metal, O. D.: ∅ 12...26; Wall thickness	Voltage withstand	500V/AC 50/60Hz 60S
Switch-point drifts [%/Sr]	≤1.0mm	Insulation resistance	≥50MΩ (500VDC)
Hysteresis range [%/Sr]	≤±20%	Vibration resistance	10...50Hz (1.5mm)
Repeat accuracy [R]	3...20%	Degree of protection	IP67
Load current	≤3%	Housing material	PBT
Residual voltage	≤200mA	Connection type	2m PVC cable

### Dimensions

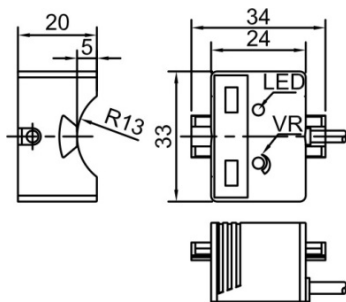

### Wiring diagram

