

Plastic Square Capacitive Sensor **CE05-S** series

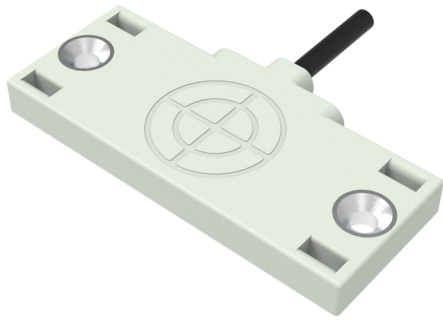

Feature description:

- 5mm ultra-thin shape
- Screw mounting and strap mounting are optional
- Adjustable detection distance
- Simultaneous detection of metallic and non-metallic objects



Model specification

NPN NO	CE05SN06DNOS	PNP NO	CE05SN06DPOS
NPN NC	CE05SN06DNCS	PNP NC	CE05SN06DPCS

Specifications

Installation	Non-flush	Protection circuit	Reverse polarity protection, Short circuit protection, overload protection
Rated distance S_n	6mm(Adjustable)	Output indicator	Yellow LED
Assured distance	2...6mm	Ambient temperature	-25°C...70°C
Shape size	20*50*5mm	Ambient humidity	35...95%RH
Output	NPN NO	Switch frequency	30Hz
Supply voltage	10...30 VDC	Impulse resistance	1000V/AC 50/60Hz 60s
Standard target	Fe 30*30*1t	Insulation resistance	$\geq 50M\Omega(500VDC)$
Switch point offset	$\leq \pm 10\%$	Vibration resistance	Complex amplitude 1.5mm 10...50Hz (2h each in X,Y,Z directions)
Hysteresis range	3...15%	Protection degree	IP67
Repeated error	$\leq 3\%$	Housing material	PBT
Load current	$\leq 100mA$	Connection	2m PVC cable
Residual voltage	$\leq 2.5V$		
Current consumption	$\leq 15mA$		

Dimensions

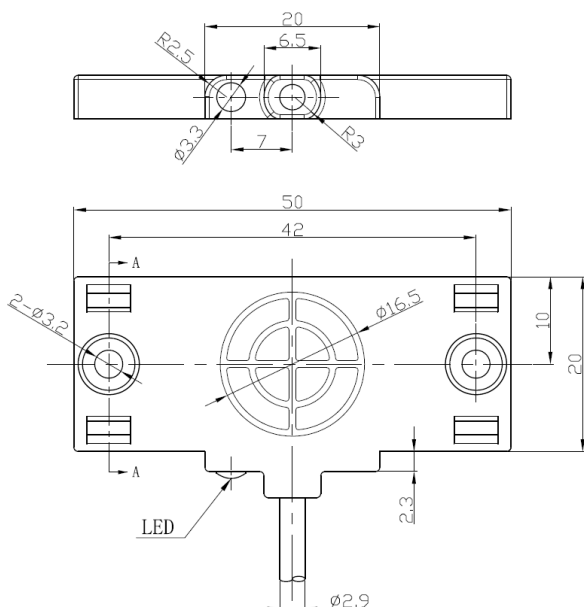

Wiring Diagram

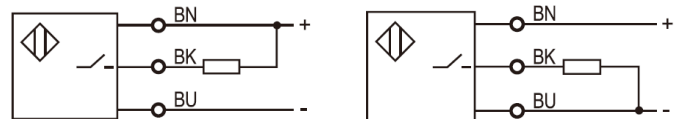

NPN NO

PNP NO

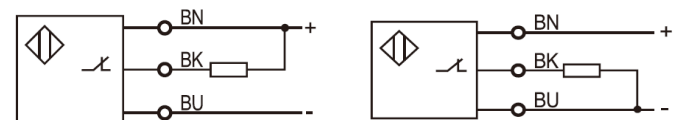

NPN NC

PNP NC